

LOC	DIST	REV	DATE	APP'D
G	14			

ZONE	LTR	DESCRIPTION	DATE	APP'D
B		REVISED PER 0720-0230-93	2/28/94	DAW

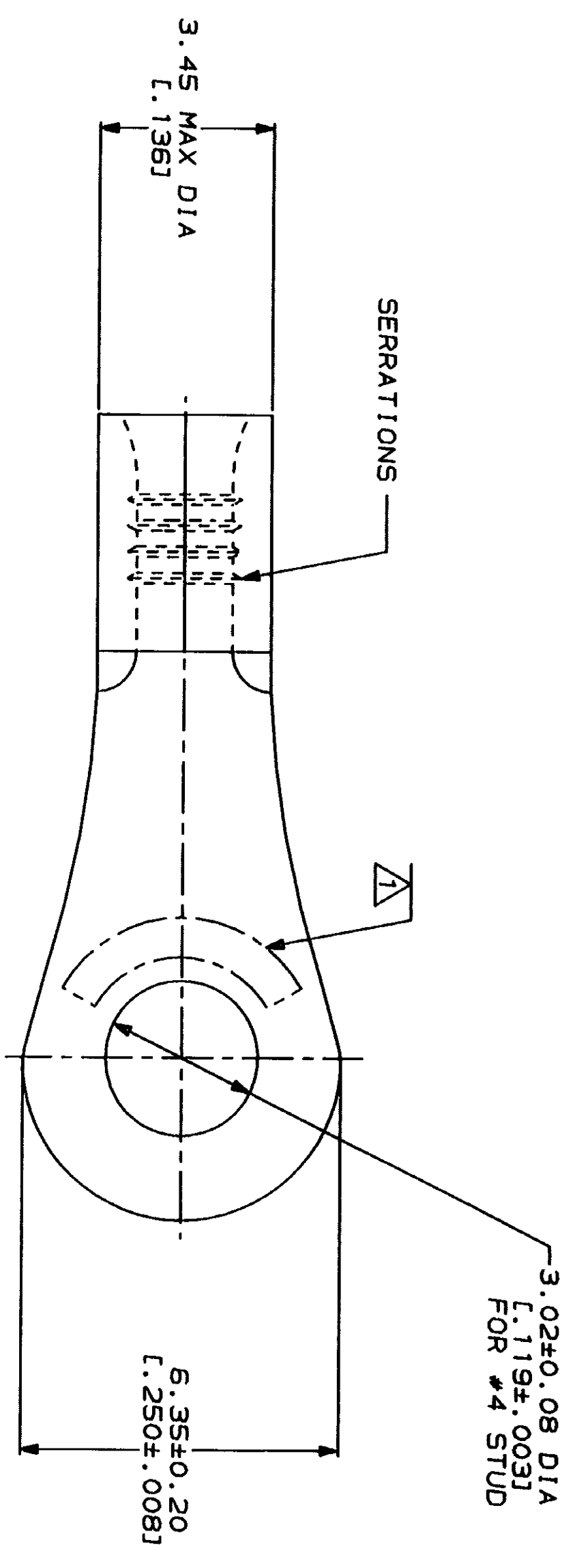
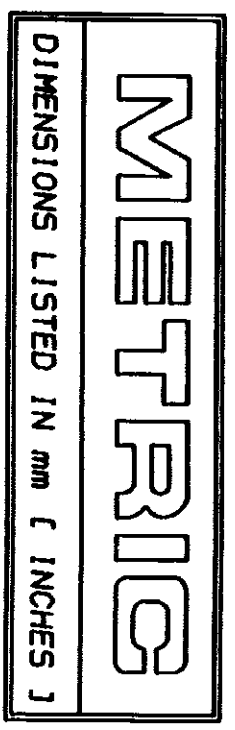

AMP WIRE RANGE 22-16 AWG STRANDED	UL E13288 Listed
LR2189 Certified	MILITARY P/N AND CLASS
NOT CERTIFIED	NOT APPLICABLE

⚠ STAMP AMP 22-18* APPROX AS SHOWN
 22-16 TERMINALS ARE STAMPED 22-18 IN
 ACCORDANCE WITH MILITARY SPECIFICATION
 MIL-T-7928, COMMERCIAL WIRE RANGE IS 22-16

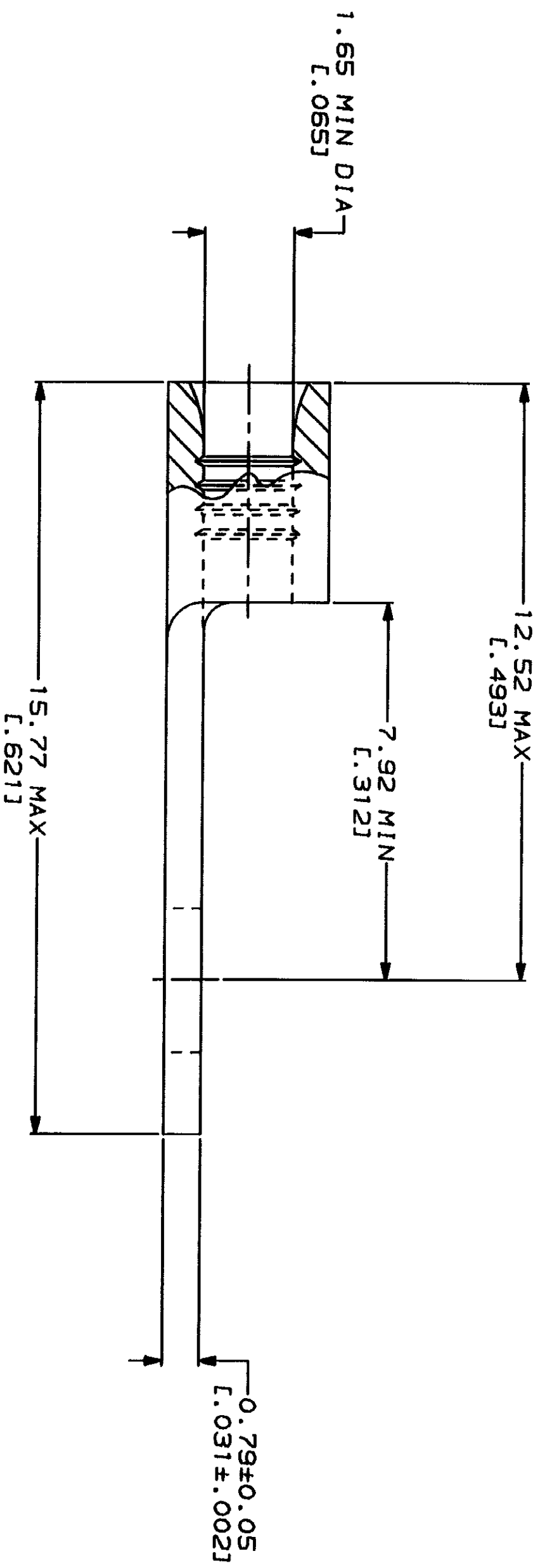

322418
 PART NO



AMP Incorporated
 Harrisburg, PA 17105-3608

TERMINAL, RING TONGUE,
 BUDGET

AMP INCORPORATED CUSTOMER SERVICE SYSTEMS		MAX RECOMMENDED OPERATING TEMPERATURE: 170°C MAX	
FOR ADDITIONAL PRODUCT INFORMATION OR COPIES OF DRAWINGS AND TECHNICAL DOCUMENTS	PRODUCT INFORMATION CENTER 1-800-522-6752	VOLTAGE RATING: NOT APPLICABLE	WIRE CROSS SECTIONAL AREA RANGE: 0.26-1.65mm ² [509-3,260] CIR MILS STRANDED
FOR APPLICATION TOOLING INFORMATION	TOOLING ASSISTANCE CENTER 1-800-722-1111	THIS DRAWING IS A GENERALIZATION FOR REFERENCE ONLY. IT IS NOT TO BE USED FOR CONSTRUCTION OF A PART OR FOR CONSTRUCTION OF A DRAWING.	
FOR ORDER ENTRY	1-800-526-5142	FINISH: TIN PLATE 0.0025±L.000100J MIN THK PER MIL-T-10727	

DO NOT SCALE PRINT. UNLESS SPECIFIED DIMENSIONS IN MILLIMETERS TOLERANCES ON: 2 PLC DEC # - 3 PLC DEC # - ANGLES # -	DR 2-3-93 TA BRINKMAN
MATERIAL: COPPER PER ASTM B-152 ANNEALED	CHK 2-3-93 DA PATTERSON
APPROD 2-3-93 DE MILLER	APPD 2-3-93 JL HECKLEY
APPLICATION SPEC	PRODUCT SPEC

SIZE	CAGE CODE	DRAWING NO
10:1	00779	322418
SCALE		